

PE35400

Document Category: Product Specification

UltraCMOS® Divide-by-4 Prescaler, 3–13.5 GHz



Peregrine
Semiconductor

Features

- High frequency support up to 13.5 GHz
- Low SSB phase noise of -135 dBc/Hz @ 3.025 GHz output frequency
- Low supply current of 16 mA
- Bare die

Applications

- Wireless communication
- Test and measurement
- Phased array radar

Figure 1 • PE35400 Functional Diagram

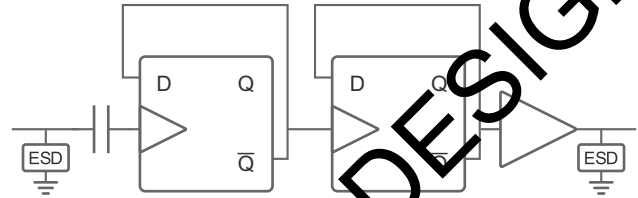

Product Description

The PE35400 is a high-performance UltraCMOS® prescaler with a fixed divide ratio of 4. It supports an operating frequency range from 3–13.5 GHz. It operates on a single voltage supply with a frequency-selecting bias resistor and draws a low current of 16 mA. The PE35400 is available in bare die.

The PE35400 is manufactured on Peregrine's UltraCMOS process, a patented variation of silicon-on-insulator (SOI) technology on a sapphire substrate, offering the performance of GaAs with the economy and integration of conventional CMOS.

NOT RECOMMENDED FOR NEW DESIGNS

Absolute Maximum Ratings

Exceeding absolute maximum ratings listed in **Table 1** may cause permanent damage. Operation should be restricted to the limits in **Table 2**. Operation between operating range maximum and absolute maximum for extended periods may reduce reliability.

ESD Precautions

When handling this UltraCMOS device, observe the same precautions as with any other ESD-sensitive devices. Although this device contains circuitry to protect it from damage due to ESD, precautions should be taken to avoid exceeding the rating specified in **Table 1**.

Latch-up Immunity

Unlike conventional CMOS devices, UltraCMOS devices are immune to latch-up.

Table 1 • Absolute Maximum Ratings for PE35400

Parameter/Condition	Min	Max	Unit
Supply voltage, V_{DD}	-0.3	3.3	V
Input power, 50 Ω		+14	dBm
Storage temperature range	-65	+150	$^{\circ}\text{C}$
ESD voltage HBM, all pins ^(*)		250	V

Note: * Human body model (MIL-STD 883 Method 3015).

Recommended Operating Conditions

Table 2 lists the recommending operating conditions for the PE35400. Devices should not be operated outside the recommended operating conditions listed below.

Table 2 • Recommended Operating Conditions for PE35400

Parameter	Min	Typ	Max	Unit
Supply voltage, V_{DD}	2.65	2.8	2.95	V
Input power, 50 Ω , based on optimal R_{BIAS} (see Figure 3), P_{IN}			+7	dBm
Operating temperature range	-40		+85	$^{\circ}\text{C}$

Electrical Specifications

Table 3 provides the PE35400 key electrical specifications @ +25 °C, $V_{DD} = 2.8V$ ($Z_S = Z_L = 50\Omega$), unless otherwise specified.

Table 3 • PE35400 Electrical Specifications^(*)

Parameter	Condition	Min	Typ	Max	Unit
Operating frequency, F_{IN}		3.0 GHz		13.5 GHz	As shown
Input power sensitivity	$F_{IN} = 3\text{--}4.5$ GHz	-5	> -7		dBm
	$F_{IN} = >4.5\text{--}11.5$ GHz	-15	> -20		dBm
	$F_{IN} = >11.5\text{--}13.5$ GHz	-1	> -1		dBm
Output power	0.75–3.375 GHz output frequency range		5		dBm
Reverse leakage	$F_{IN} = 3\text{--}13.5$ GHz, $P_{IN} = 0$ dBm		-45		dBm
SSB phase noise	3.025 GHz output frequency @ 100 kHz offset, $P_{IN} = 0$ dBm		-135		dBc/Hz
Supply current, I_{DD}	$F_{IN} = 8$ GHz		16		mA

Note: * All values in Min/Max columns are guaranteed by design characterization.

NOT RECOMMENDED FOR NEW DESIGNS

Device Functional Considerations

The PE35400 divides a 3.0–13.5 GHz input signal by four, producing a 750 MHz to 3.375 GHz output signal. In order for the prescaler to work properly, several conditions need to be adhered to. It is crucial that V_{BYP} and V_{DD} are supplied with bypass capacitors to ground. In addition, the output signal RF_{OUT} needs to be AC coupled (via an external capacitor), as shown in **Figure 2**. The input frequency range is selected by the value of R_{BIAS} according to **Figure 3**. The ground pattern on the board should be made as wide as possible to minimize ground impedance.

Figure 2 • Circuit Block Diagram for PE35400(*)

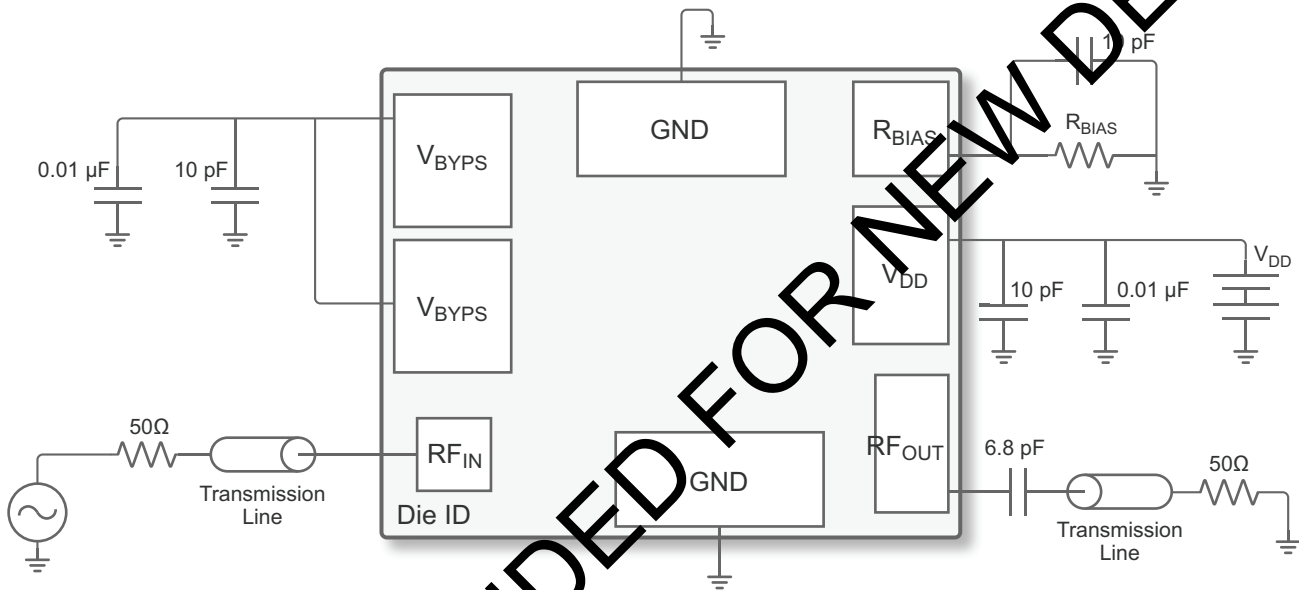

Note: * For optimal performance, the following bond wire configuration is recommended. V_{BYP} : 2 bond wires per pad. RF_{IN} : 1 bond wire. GND : 3 bond wires per pad. RF_{OUT} : 2 bond wires. V_{DD} : 2 bond wires. R_{BIAS} : 1 bond wire.

NOT RECOMMENDED FOR NEW DESIGNS

Typical Performance Data

Figure 3 through Figure 11 show the typical performance data @ +25 °C, $V_{DD} = 2.8V$ ($Z_S = Z_L = 50\Omega$), based on optimal R_{BIAS} as shown in Figure 3, unless otherwise specified.

Figure 3 • Frequency vs R_{BIAS}

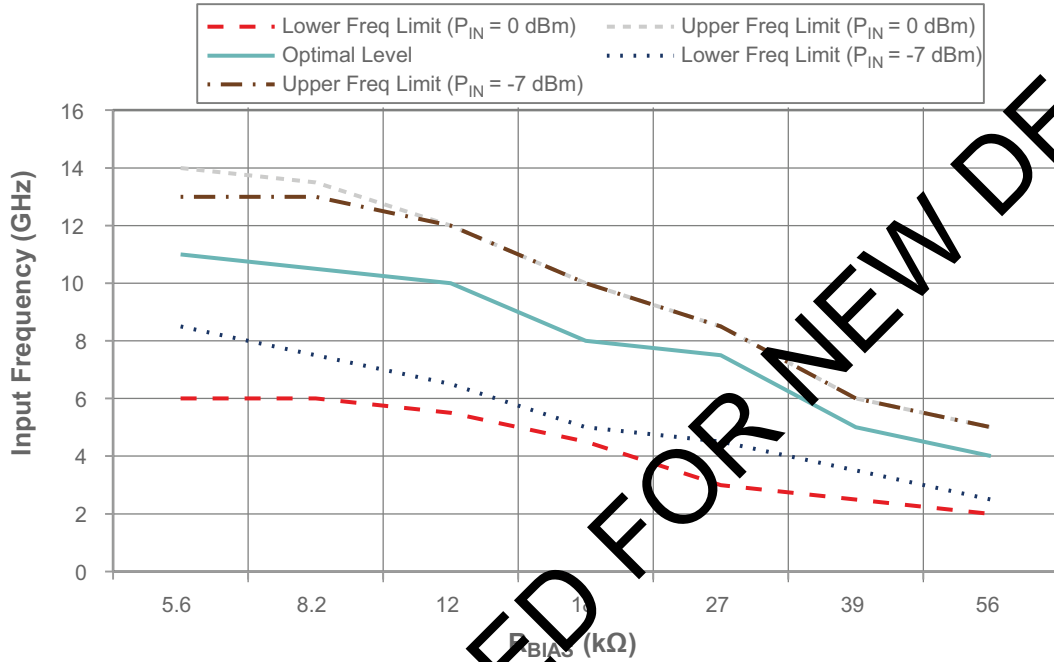

NOT RECOMMENDED FOR NEW DESIGNS

Figure 4 • Input Power Sensitivity

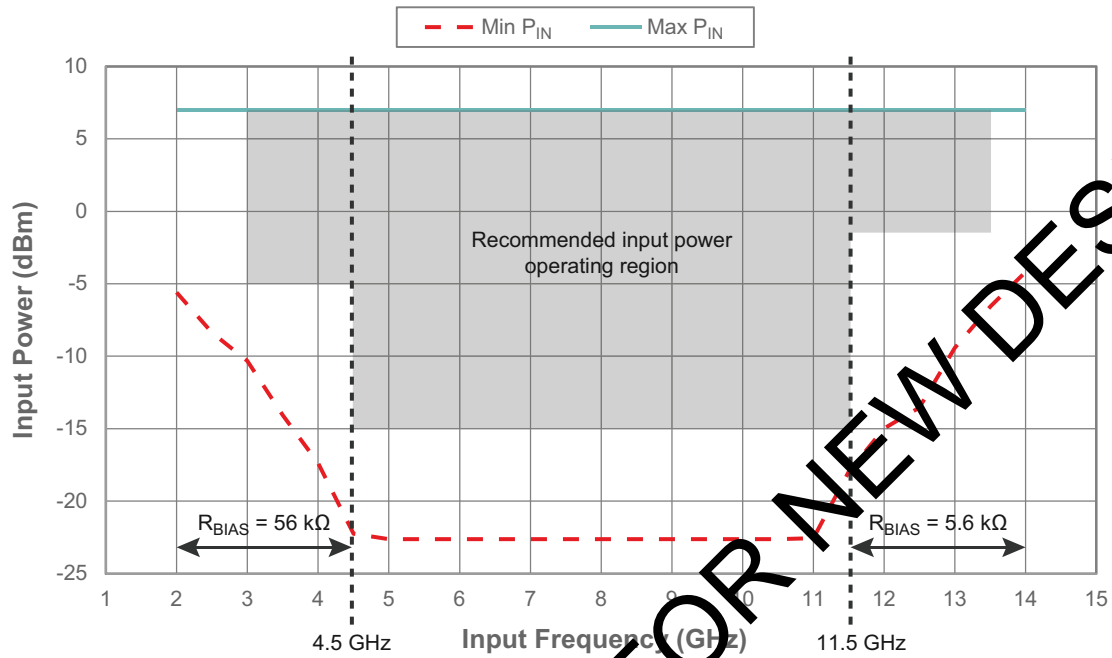
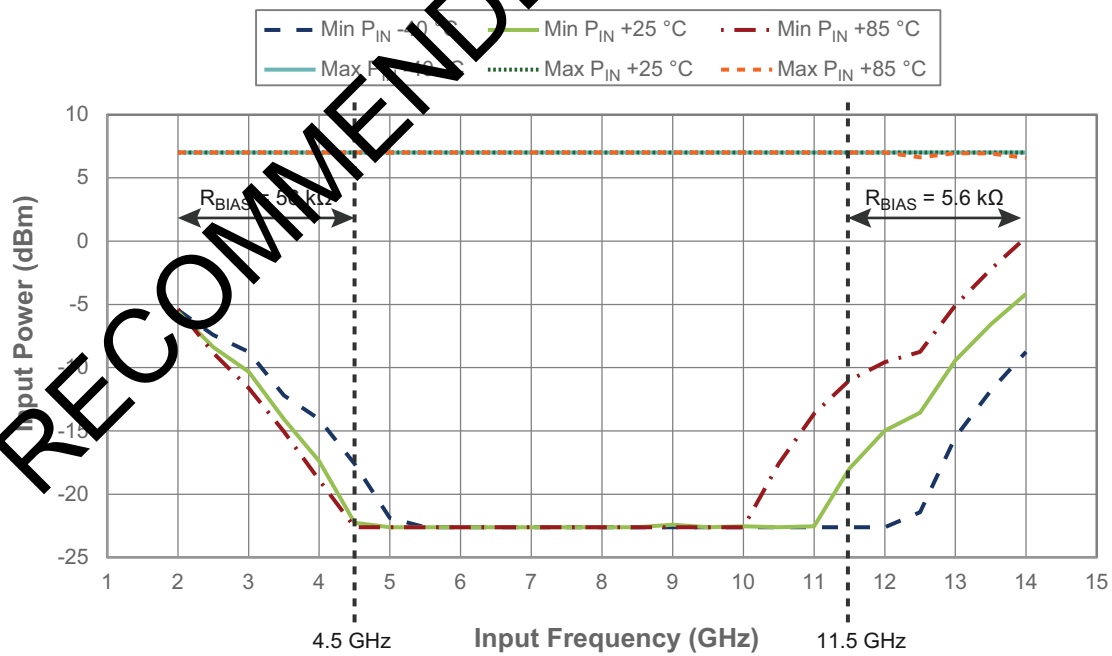

Figure 5 • Input Power Sensitivity vs Temperature



NOT RECOMMENDED FOR NEW DESIGNS

Figure 6 • Output Power vs V_{DD}

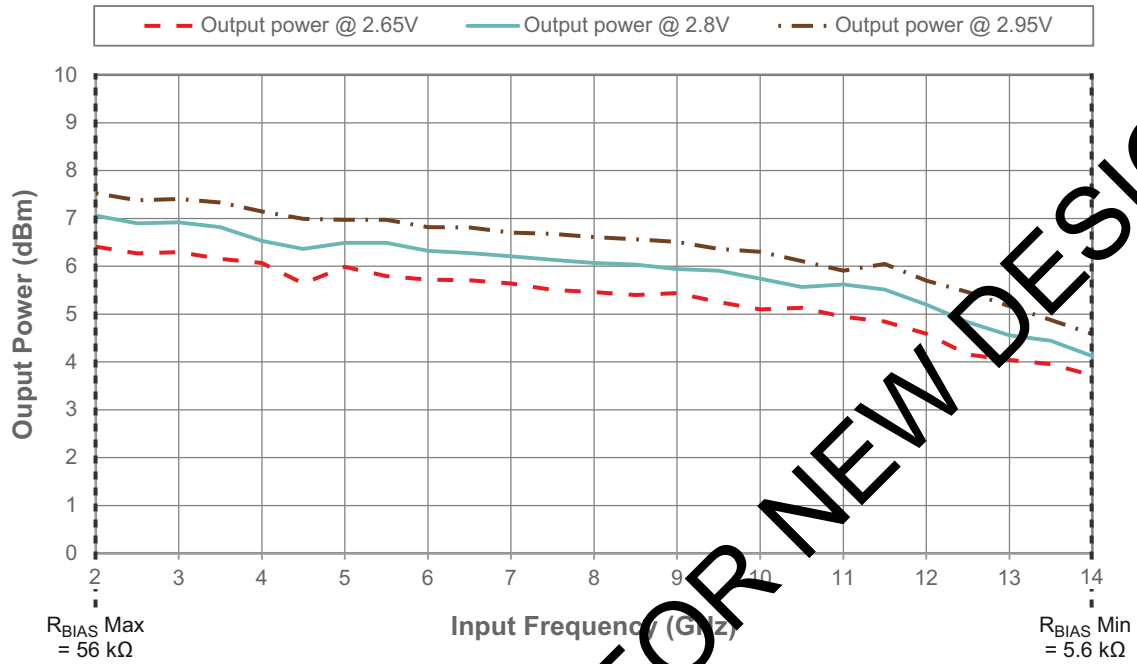
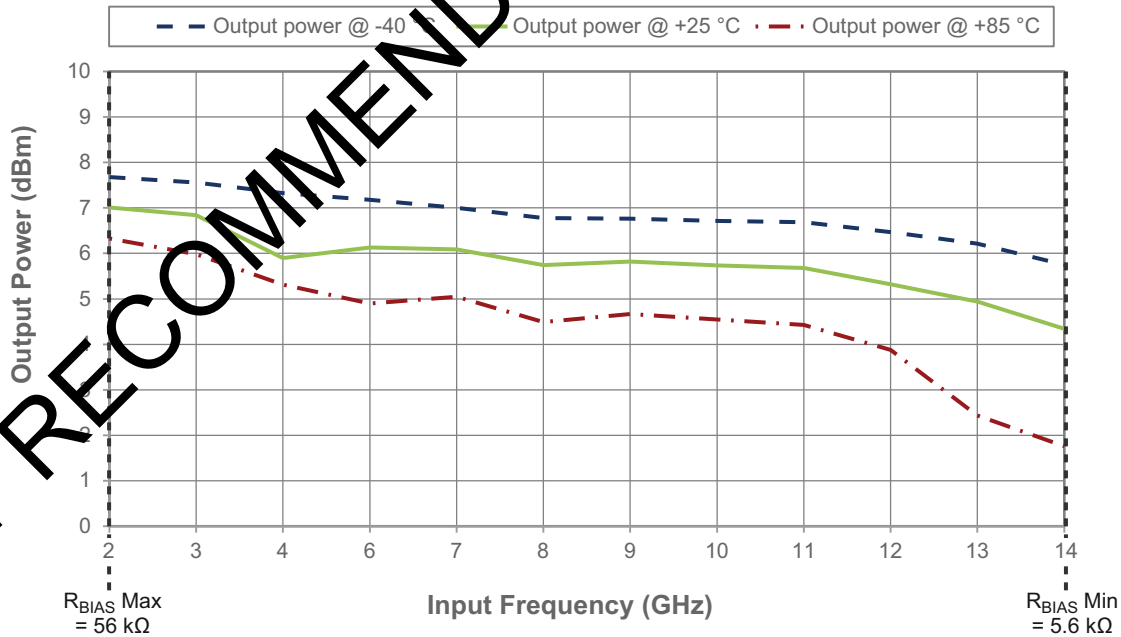

Figure 7 • Output Power vs Temperature



NOT RECOMMENDED FOR NEW DESIGNS

Figure 8 • SSB Phase Noise @ 3.025 GHz Output Frequency, $P_{IN} = 0$ dBm

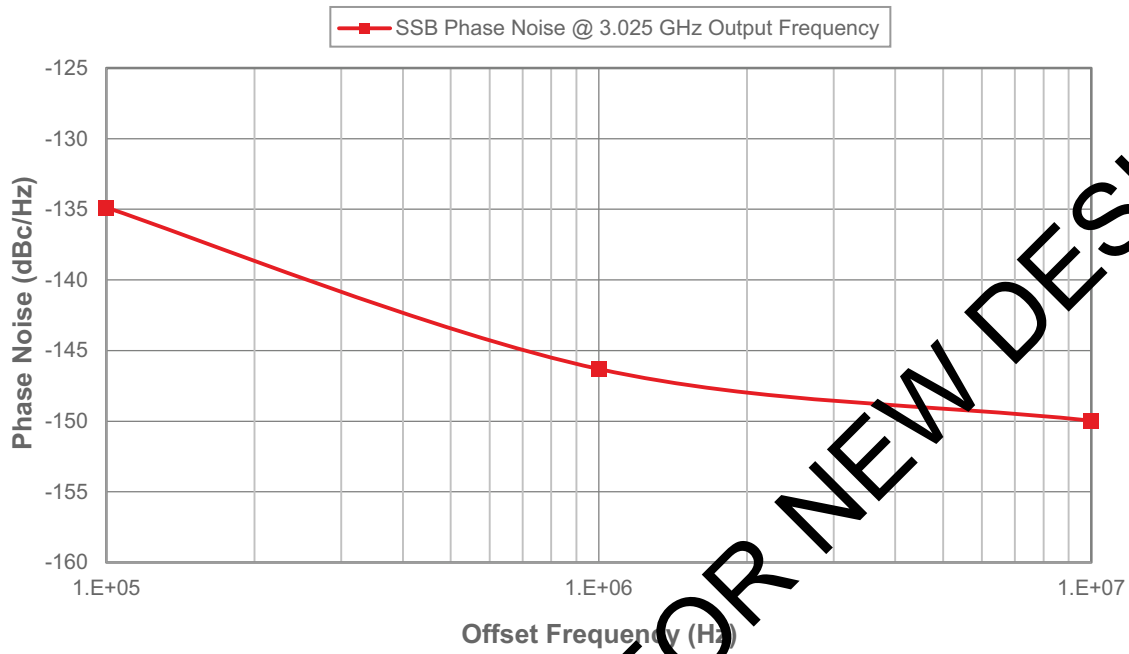
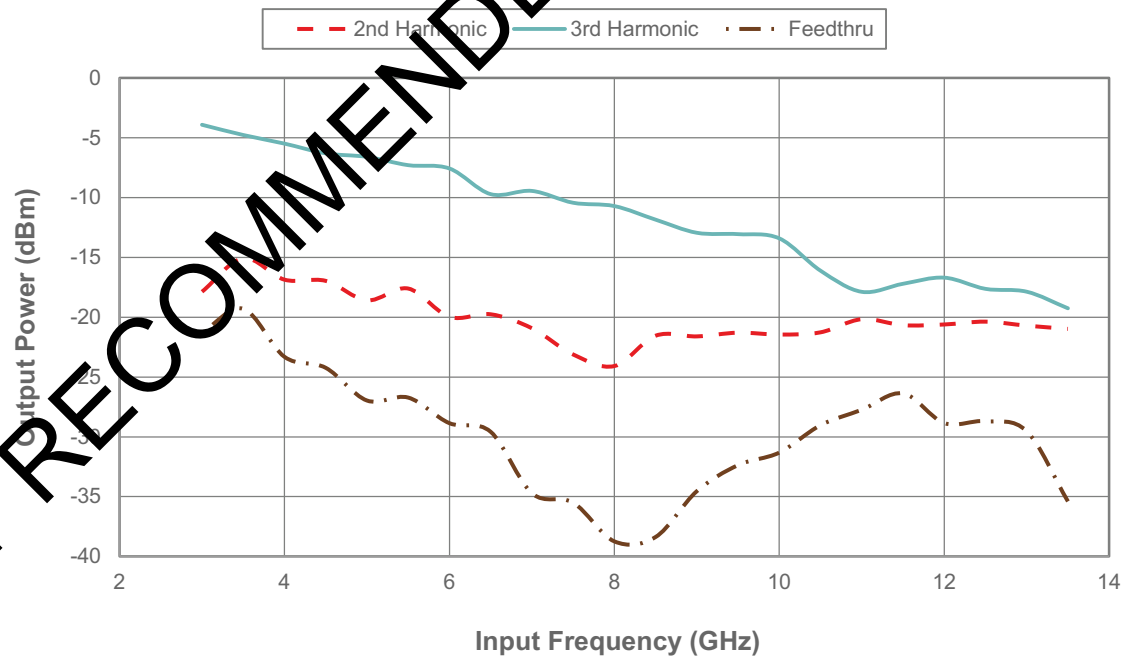

Figure 9 • Output Harmonics, $P_{IN} = 0$ dBm



NOT RECOMMENDED FOR NEW DESIGNS

Figure 10 • I_{DD} vs R_{BIAS}

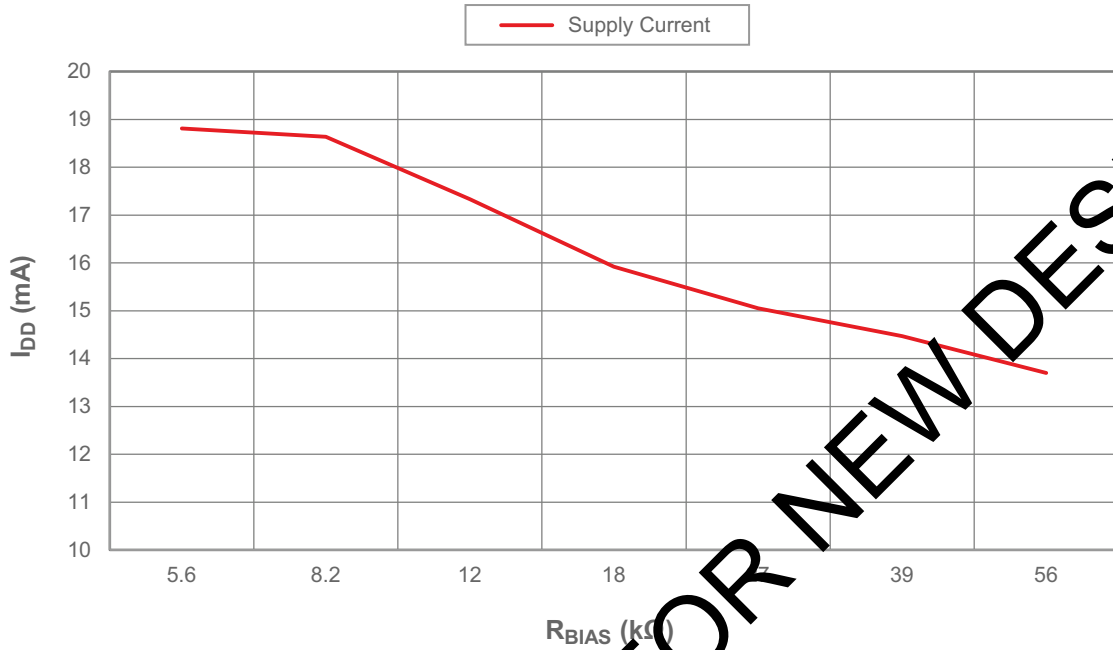
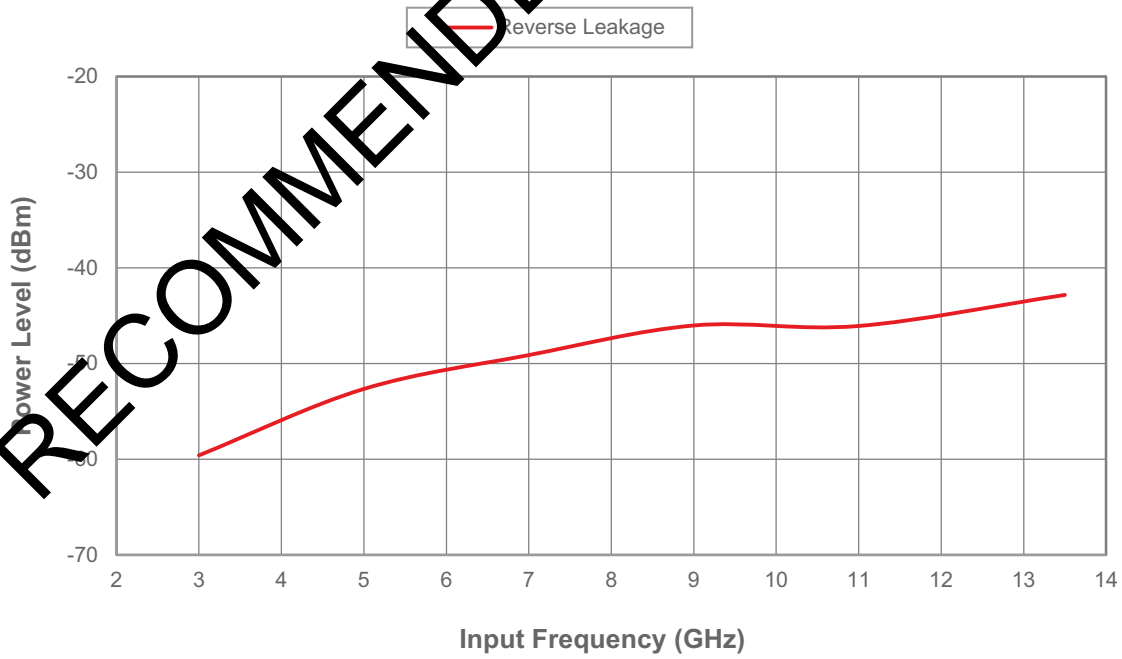

Figure 11 • Reverse Leakage, $P_{IN} = 0$ dBm



NOT RECOMMENDED FOR NEW DESIGNS

Pad Configuration

This section provides pad information for the PE35400. Figure 12 shows the pad configuration of this device. Table 4 provides a description for each pad.

Figure 12 • Pad Configuration (Top View)

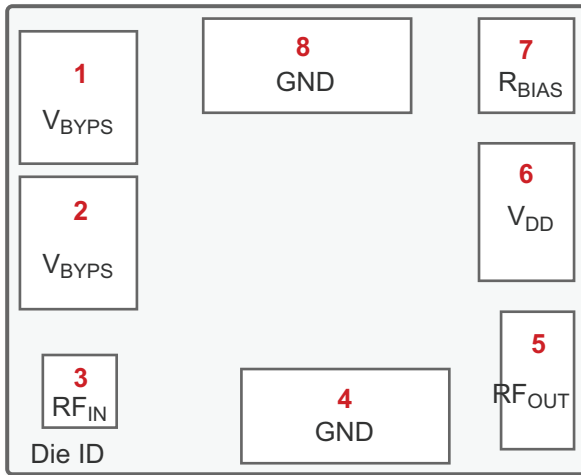

Table 4 • Pad Descriptions for PE35400

Pad No.	Pad Name	Description
1	V _{BYPS}	Prescaler supply bypass
2	V _{BYPS}	Prescaler supply bypass
3	RF _{IN}	RF input
4	GND	Ground
5	RF _{OUT}	RF output
6	V _{DD}	Supply voltage
7	R _{BIAS}	Frequency selecting bias resistor
8	GND	Ground

NOT RECOMMENDED FOR NEW DESIGNS

Die Mechanical Specifications

This section provides the die mechanical specifications for the PE35400.

Table 5 • Mechanical Specifications for PE35400

Parameter	Min	Typ	Max	Unit	Condition
Die size, singulated (x,y)	866 × 716	886 × 736	916 × 766	μm	Including excess sapphire, max tolerance = -20/+30 μm
Wafer thickness	180	200	220	μm	
Wafer size		150		mm	

Table 6 • Pad Coordinates for PE35400^(*)

Pad No.	Pad Name	Pad Center (μm)		Pad Opening Size (μm)	
		X	Y	X	Y
1	V _{BYP} S	-303	198	160	180
2	V _{BP} YS	-303	-3	160	180
3	RF _{IN}	-303	-208	100	100
4	GND	68	-243	290	130
5	RF _{OUT}	333	-193	100	190
6	V _{DD}	318	40	130	190
7	R _{BIAS}	318	243	160	130
8	GND	14	243	290	130

Note: * All pad locations originate from the die center and refer to the center of the pad.

Figure 13 • Pad Layout for PE35400⁽¹⁾⁽²⁾

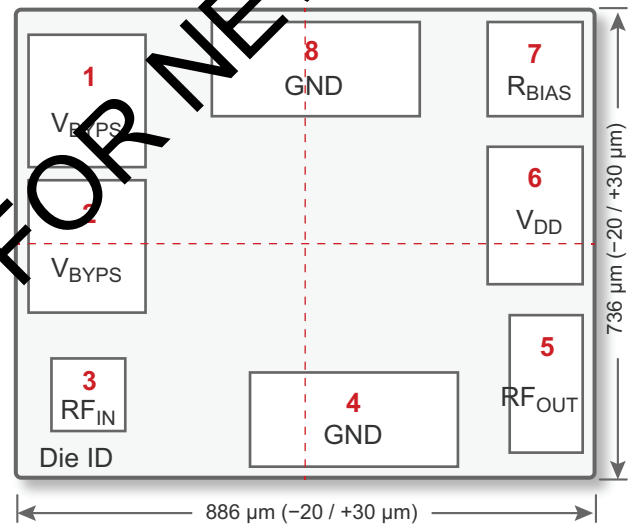

Notes:

- 1) Drawings are not drawn to scale.
- 2) Singulated die size shown, pad side up.

NOT RECOMMENDED FOR NEW DESIGNS

Waffle Pack Information

Figure 14 provides the waffle pack information for the PE35400.

Figure 14 • 2 × 2 Inch Waffle Pack for PE35400⁽¹⁾⁽²⁾⁽³⁾

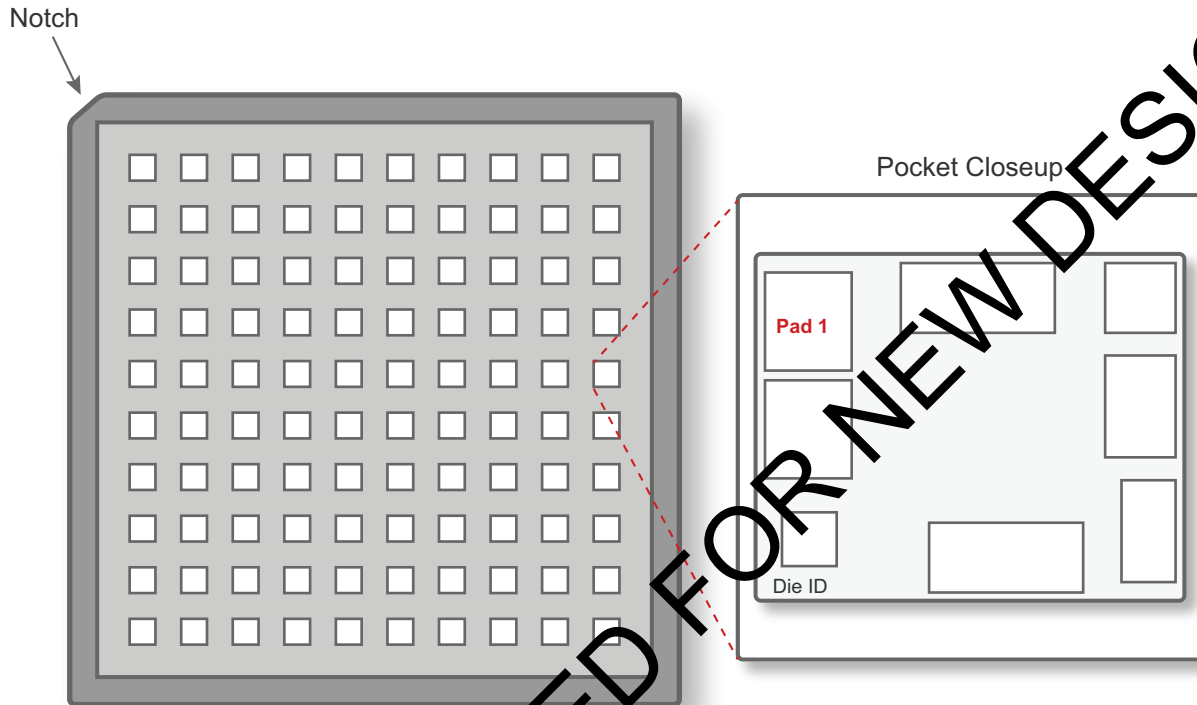

Notes:

- 1) Drawings are not drawn to scale.
- 2) Die in pocket shown pad side up.
- 3) Die will be oriented in the same direction (up and down) within all waffle packs. Unless otherwise stated, die will be oriented such that the top left corner of die will be in-line with the "notched" corner of the die plate base and corner. The die base cover label will be affixed on the die base cover such that the top of the label indicates the top of the die within the waffle pack.

Ordering Information

Table 7 lists the available ordering code for the PE35400 as well as available shipping method.

Table 7 • Order Code for PE35400

Order Codes	Description	Packaging	Shipping Method
PE35400A–G	PE35400 die	Die in 2 × 2 inch waffle pack	100 die/waffle pack

Document Categories

Advance Information

The product is in a formative or design stage. The datasheet contains design target specifications for product development. Specifications and features may change in any manner without notice.

Preliminary Specification

The datasheet contains preliminary data. Additional data may be added at a later date. Peregrine reserves the right to change specifications at any time without notice in order to supply the best possible product.

Product Specification

The datasheet contains final data. In the event Peregrine decides to change the specifications, Peregrine will notify customers of the intended changes by issuing a CNF (Customer Notification Form).

Sales Contact

For additional information, contact Sales at sales@psemi.com.

Disclaimers

The information in this document is believed to be reliable. However, Peregrine assumes no liability for the use of this information. Use shall be entirely at the user's own risk. No patent rights or licenses to any circuits described in this document are implied or granted to any third party. Peregrine's products are not designed or intended for use in devices or systems intended for surgical implant, or in other applications intended to support or sustain life, or in any application in which the failure of the Peregrine product could create a situation in which personal injury or death might occur. Peregrine assumes no liability for damages, including consequential or incidental damages, arising out of the use of its products in such applications.

Patent Statement

Peregrine products are protected under one or more of the following U.S. patents: patents.psemi.com

Copyright and Trademark

©2015, Peregrine Semiconductor Corporation. All rights reserved. The Peregrine name, logo, UTSi and UltraCMOS are registered trademarks and HaRP, MultiSwitch and DuNE are trademarks of Peregrine Semiconductor Corp.