

PE43620

Document Category: Product Specification

50 Ω RF Digital Attenuator 2-bit, 0, 6, 12, and 18 dB



Features

- Fast switching speed: Typical 26 ns
- High linearity: Typical +61 dBm IP3
- Small α -Error
- Attenuation: 0, 6, 12, and 18 dB states
- Parallel control
- CMOS compatible
- Packaged in a 12-lead 3x3x0.85 mm QFN

Applications

- Wireless infrastructure
 - Rx AGC
 - Coarse signal conditioning
- Military / land mobile radios
 - General purpose RF/IF gain control

Figure 1 • PE43620 Functional Diagram

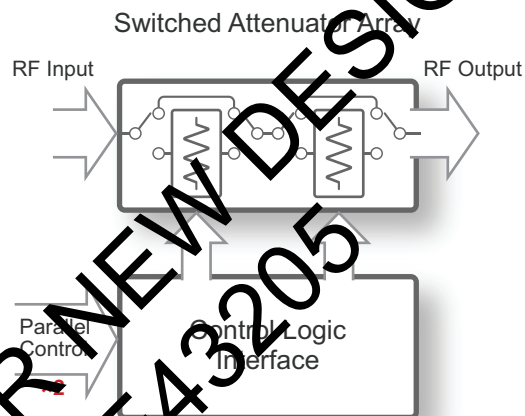

Product Description

The PE43620 is a 50 Ω , high linearity, 2-bit RF digital step attenuator (DSA) covering an 18dB attenuation range in 6 dB steps. With a parallel control interface, it maintains high attenuation accuracy, fast switching speed, low insertion loss and low power consumption. This Peregrine DSA is available in a 3x3 mm 12-lead QFN footprint.

The PE43620 is manufactured on Peregrine's UltraCMOS process, a patented variation of silicon-on-insulator (SOI) technology on a sapphire substrate, offering the performance of GaAs with the economy and integration of conventional CMOS.

Absolute Maximum Ratings

Exceeding absolute maximum ratings listed in **Table 1** may cause permanent damage. Operation should be restricted to the limits in **Table 2**. Operation between operating range maximum and absolute maximum for extended periods may reduce reliability.

ESD Precautions

When handling this UltraCMOS device, observe the same precautions as with any other ESD-sensitive devices. Although this device contains circuitry to protect it from damage due to ESD, precautions should be taken to avoid exceeding the rating specified in **Table 1**.

Latch-up Immunity

Unlike conventional CMOS devices, UltraCMOS devices are immune to latch-up.

Table 1 • Absolute Maximum Ratings for PE43620

Parameter/Condition	Min	Max	Unit
Power supply voltage	-0.3	4.0	V
Voltage on any Digital input	-0.3	V _{DD} + 0.3	V
Storage temperature range	-65	150	°C
Input power (50Ω) 20 MHz ≤ 4.0 GHz		+23	dBm
ESD voltage (Human Body Model, MIL_STD 883 Method 3015.7)		2000	V

NOT RECOMMENDED FOR NEW DESIGNS
REPLACE WITH PE43205

Recommended Operating Conditions

Table 2 lists the recommending operating conditions for the PE43620. Devices should not be operated outside the operating conditions listed below.

Table 2 • Recommended Operating Conditions for PE43620

Parameter	Min	Typ	Max	Unit
V _{DD} Power Supply Voltage	3.0	3.3	3.6	V
I _{DD} Power Supply Current		8	200	μA
Digital Input High	0.7xV _{DD}		3.6	V
Digital Input Low	0		0.3xV _{DD}	V
Digital Input Leakage			10	μA
P _{IN} Input power (50Ω) 20 MHz ≤ 4.0 GHz			+23	dBm
T _{OP} Operating temperature range	-40	25	85	°C

NOT RECOMMENDED FOR NEW DESIGNS
REPLACE WITH PE43205

Electrical Specifications

Table 3 provides the PE43620 key electrical specifications @ +25°C, VDD = 3.3V, unless otherwise specified.

Table 3 • PE43620 Electrical Specifications @ +25°C, V_{DD} = 3.3V

Parameter	Condition	Min	Typ	Max	Unit
Frequency Range			50 - 3000		MHz
Attenuation Range	6 dB, 12 dB and 18 dB steps		0 - 18		dB
Insertion Loss			0.6	0.7	dB
Attenuation Error	0 dB - 18 dB attenuation settings		+0.1	-0.25 / +0.40	dB
	50 MHz to < 2000 MHz		-0.2	-0.10 / +0.50	dB
	2000 MHz – 3000 MHz				dB
Return Loss			15		dB
Relative Phase	All states		11		deg
P1dB	Input	+28	+30		dBm
IIP3	IIP3 Two tones at +18 dBm, 20 MHz spacing		+61		dBm
Switching Time	50% DC CTRL to 10% / 90% RF		26		ns

Switching Frequency

Switching frequency is defined to be the speed at which the DSA can be toggled across attenuation states. Switching time is the time duration between the point the control signal reached 50% of the final value and the point the output signal reaches within 10% or 90% of its target value.

The PE43620 has a maximum 25 kHz switching rate.

Truth Table

Table 4 provides attenuation settings.

Table 4 • Attenuation Word Truth Table

C1	C2	Attenuation Setting RF1-RF2
L	L	Reference I.L.
H	L	6 dB
L	H	12 dB
H	H	18 dB

Typical Performance Data

Figure 2–Figure 11 show the typical performance data at @ T = +25C, unless otherwise specified.

Figure 2 • Attenuation vs. Attenuation Setting

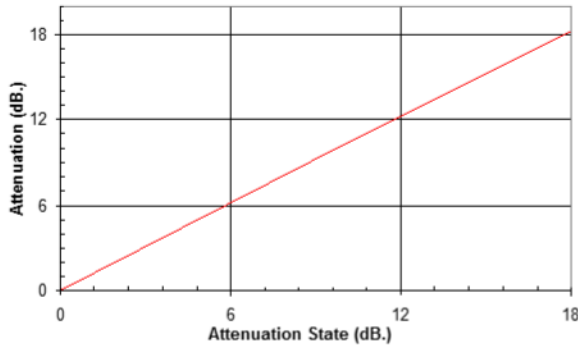

Figure 3 • Attenuation Error vs. Frequency @ 25C⁽¹⁾

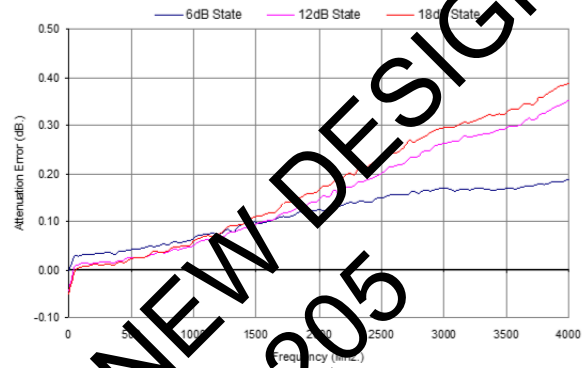

Figure 4 • Insertion Loss vs. Temperature

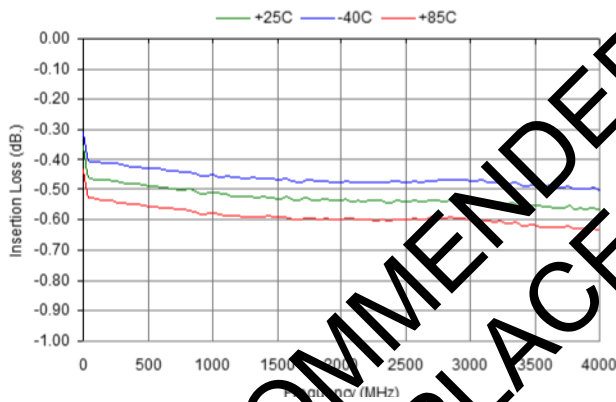

Figure 5 • Input Return Loss vs Attenuation @ T = +25C

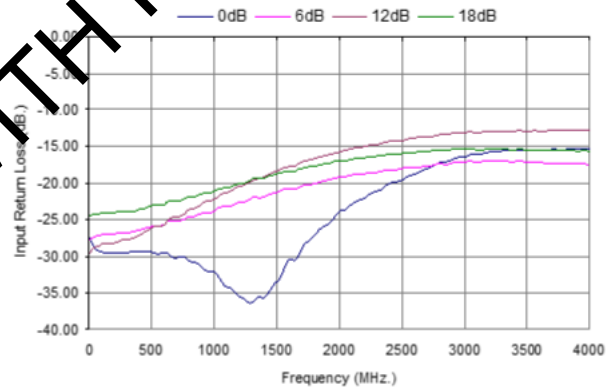

Figure 6 • Output Return Loss vs. Attenuation @ T = +25C

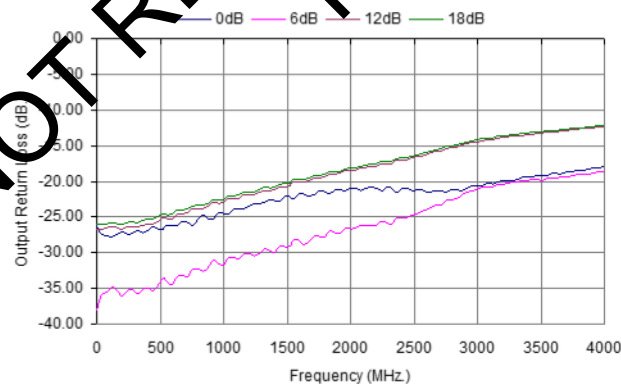

Figure 7 • Input Return Loss vs Temperature @ 12 dB State

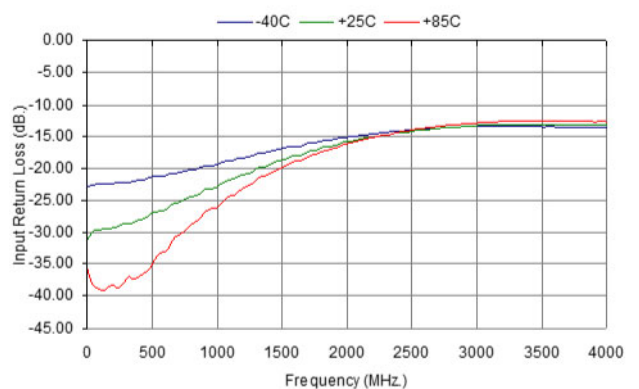

Figure 8 • Output Return Loss vs Temperature @ 12 dB State

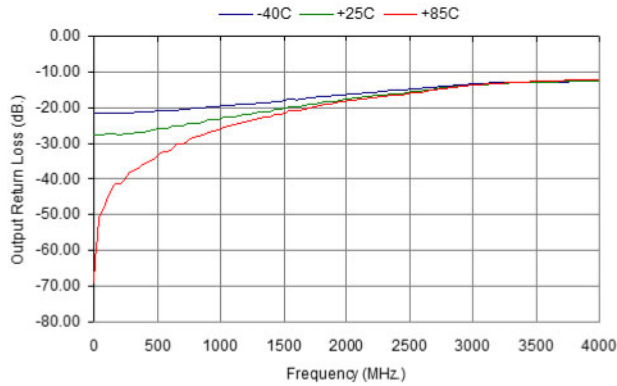

Figure 9 • Relative Phase⁽²⁾ vs Frequency @ T = +25C

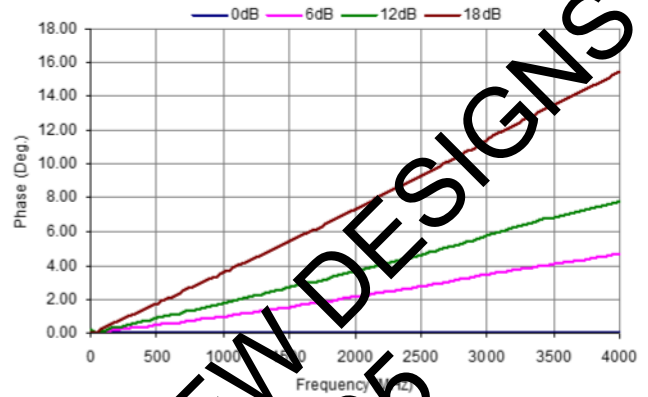

Figure 10 • Input IP3 vs Attenuation Setting @ T = +25C

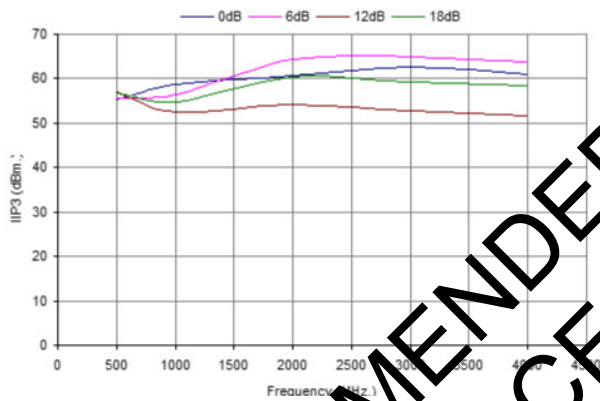
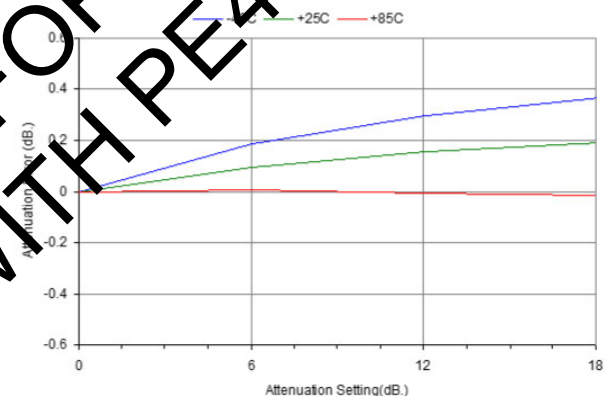

Figure 11 • Attenuation Error vs. Attenuation Setting @ 3000 MHz



- 1) Attenuation Error Equation - $AE = ABS(ABS(Insertion Loss @ Attenuation Setting) - ABS(Reference Loss)) - [ABS(Attenuation Setting)]$
- 2) Relative Phase = Phase (attenuation state) - Phase (insertion loss state)

NOT RECOMMENDED FOR NEW DESIGNS
REPLACE WITH PE43205

Pin Information

This section provides pinout information for the PE43620. **Figure 12** shows the pin map of this device for the available package. **Table 5** provides a description for each pin.

Figure 12 • Pin Configuration (Top View)

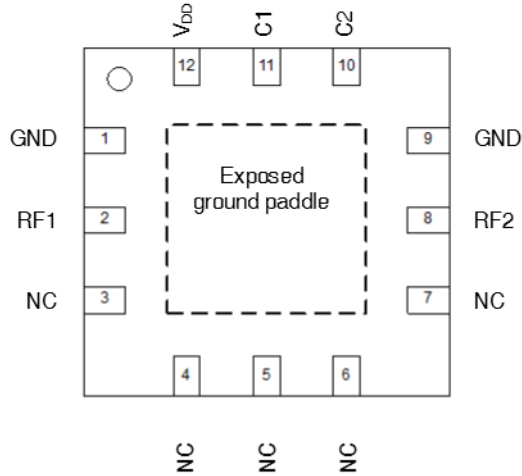

Table 5 • Pin Descriptions for PE43620

Pin No.	Pin Name	Description
1	GND	Ground
2	RF1 ²	RF1 port
3	NC ¹	No connect
4	NC ¹	No connect
5	NC ¹	No connect
6	NC ¹	No connect
7	NC ¹	No connect
8	RF2	RF2 port
9	GND	Ground
10	C2	Attenuation control bit, 12 dB
11	C1	Attenuation control bit, 6 dB
12	V _{DD}	Power supply pin

Notes: 1. Pins 3 through 7 may be tied to ground if desired, but they are not connected to ground internal to the package. 2. All RF pins must be DC blocked with an external series capacitor or held at 0 VDC..

NOT RECOMMENDED FOR NEW DESIGNS
REPLACE WITH PE43205

Packaging Information

This section provides packaging data including the moisture sensitivity level, package drawing, package marking and tape-and-reel information.

Moisture Sensitivity Level

The moisture sensitivity level rating for the PE43620 in the 12-lead 3x3 QFN package is MSL 1.

Package Drawing

Figure 13 • Package Mechanical Drawing for 12-lead 3x3 QFN

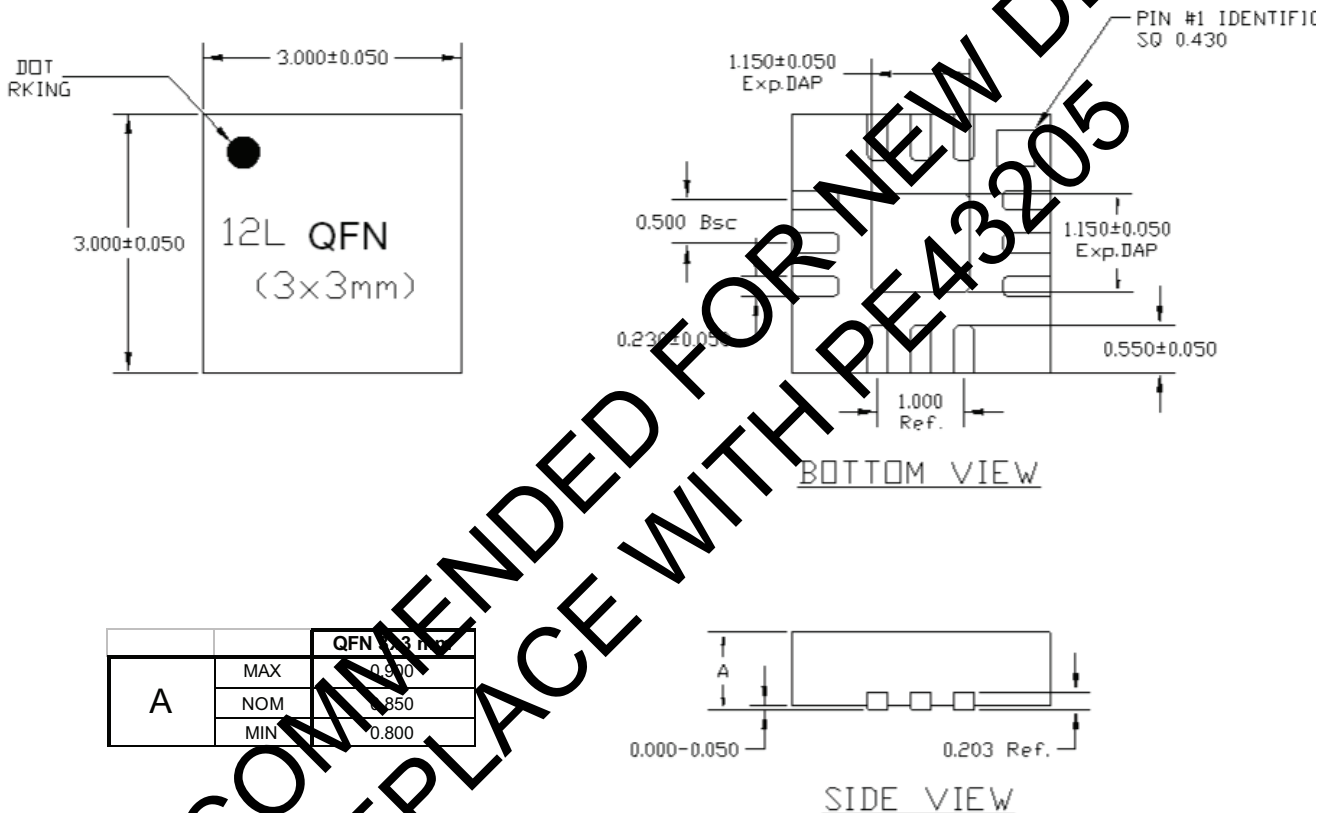

Note: * Pin 1 Identification tab is electrically connected to the exposed ground paddle.

Top-Marking Specification

Figure 14 • Package Marking Specifications for PE43620



- = Pin 1 indicator
- YY = Last two digits of assembly year
- WW = Assembly work week
- ZZZZZZ = Assembly lot code (maximum six characters)

Tape and Reel Specification

Figure 15 • Tape and Reel Specifications for 12-lead 3x3 QFN

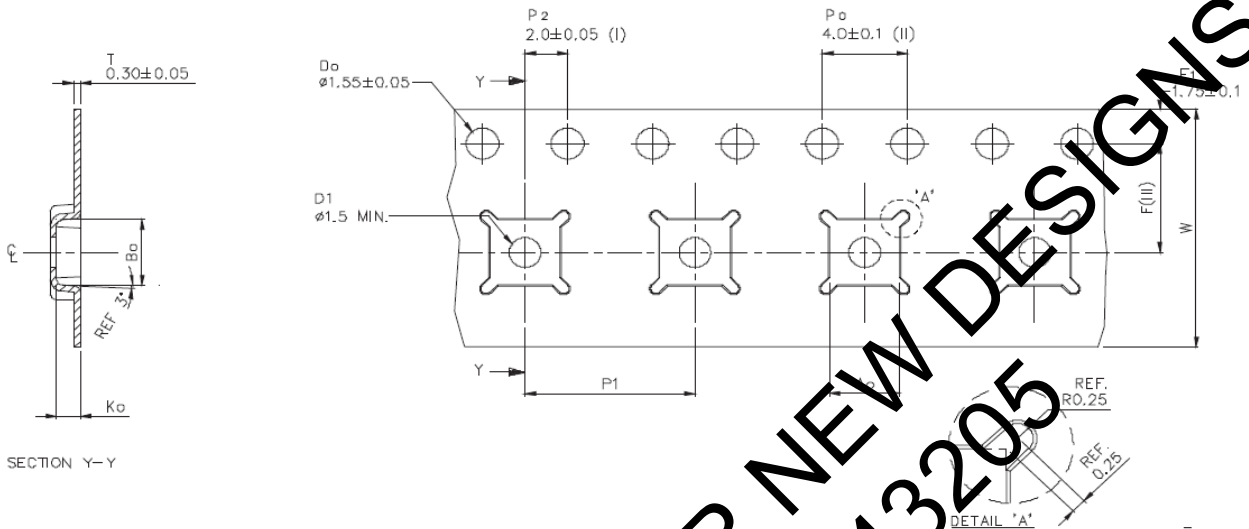

Direction of Feed

A ₀	3.30 +/- 0.1
B ₀	3.30 +/- 0.1
K ₀	1.10 +/- 0.1
F	5.50 +/- 0.05
P ₁	8.00 +/- 0.1
W	12.00 +/- 0.3

- (I) Measured from centreline of sprocket hole to centreline of pocket.
 - (II) Cumulative tolerance of 10 sprocket holes is ±0.1.
 - (III) Measured from centreline of sprocket hole to centreline of pocket.
 - (IV) Other material available.
- ALL DIMENSIONS IN MILLIMETERS UNLESS OTHERWISE STATED.

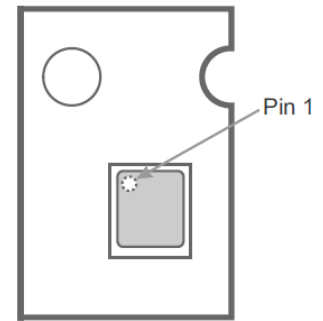

Device Orientation in Tape

NOT RECOMMENDED FOR NEW DESIGNS
REPLACE WITH PE43205

Ordering Information

Table 6 lists the available ordering codes for the PE43620 as well as available shipping methods.

Table 6 • Order Codes for PE43620

Order Codes	Description	Packaging	Shipping Method
PE43620A-Z	PE43620 Digital Step Attenuator	Green 12-lead 3x3 mm QFN	300 units / T & R
EK43620-01	PE43620 Evaluation Kit	Evaluation Kit	1 / Box

Document Categories

Advance Information

The product is in a formative or design stage. The datasheet contains design target specifications for product development. Specifications and features may change in any manner without notice.

Preliminary Specification

The datasheet contains preliminary data. Additional data may be added at a later date. pSemi reserves the right to change specifications at any time without notice in order to supply the best possible product.

Product Specification

The datasheet contains final data. In the event pSemi decides to change the specifications, pSemi will notify customers of the intended changes by issuing a CNF (Customer Notification Form).

Sales Contact

For additional information, contact Sales at sales@psemi.com.

Disclaimers

The information in this document is believed to be reliable. However, pSemi assumes no liability for the use of this information. Use shall be entirely at the user's own risk. No patent rights or licenses to any circuits described in this document are implied or granted to any third party. pSemi's products are not designed or intended for use in devices or systems intended for surgical implant, or in other applications intended to support or sustain life, or in any application in which the failure of the pSemi product could create a situation in which personal injury or death might occur. pSemi assumes no liability for damages, including consequential or incidental damages, arising out of the use of its products in such applications.

Patent Statement

pSemi products are protected under one or more of the following U.S. patents: patents.psemi.com

Copyright and Trademark

©2018, pSemi Corporation. All rights reserved. The Peregrine Semiconductor name, Peregrine Semiconductor logo and UltraCMOS are registered trademarks and the pSemi name, pSemi logo, HaRP and DuNE are trademarks of pSemi Corporation in the U.S. and other countries.